

# A Unity Power Factor Multiple Isolated Output Switching Mode Power Supply Using AC-DC Converter

Tanupriya sahu<sup>1</sup>, Alok Sahu<sup>2</sup>, M.K Pradhan<sup>3</sup>

*M.Tech Scholar (Power Electronics), Dept. of Electronics & Communication<sup>1</sup>, MATS University  
Gullu-Aarang, Raipur (C.G.)*

*Asst. Professor, Dept. of electronics & communication<sup>2</sup>,  
Gullu-Aarang, Raipur (C.G.)*

*Head of department, Dept. of electronics & communication<sup>3</sup>,  
Gullu-Aarang, Raipur (C.G.)*

*tpsahu97@gmail.com<sup>1</sup>, aloksahu121@gmail.com<sup>2</sup>, Pradhan.mahendra@gmail.com<sup>3</sup>*

**Abstract**-Switched Mode Power Supplies have become increasingly popular for efficient methods of delivering power to electronic devices. This method of using a current fed push pull converter. While most AC-DC converters utilize a bridge rectifier, the proposed circuit will utilize, this circuit will also inherently power factor correction. This power factor correction circuit is capable to perform the AC to DC conversion without the diode bridge rectifier and able to obtain low output voltage. The deal small signal and steady state analysis of the converter operated in discontinuous conduction mode (DCM).AC main switching are, including isolation techniques using opt couplers, to control a bidirectional switch. Simulations results with MATLAB has been shown.

**Keywords**-PFC; PI controller;Bridgeless rectifier;THD;DCM.

## 1. INTRODUCTION

SMPS with active power factor correction are necessary for many types of electric equipment to convert line frequency ac to dc output voltage from a major part of load on the utility. Power factor correction is reduce in SMPS the voltage and current distortion and losses. The power quality leading to very low power facto around 0.48, the total harmonics Distortion (THD) of input current is 83.5%. Due to problems associated with low Power factor and harmonics. There is converter for step up such as buck converter, boost converter, buck-boost converter and Cuk converter .a buck converter is a step-up boost converter it is a SMPS that uses two switches an inductor and capacitor [2].

The bridgeless converter is proposed and this type of DC-DC converter. The non-isolated PFC converter. At the front end of these power supplies is a commonly used. The bridgeless rectifier reduces the switching losses and conduction loss because of having reduced number of switching. A new bridgeless single-phase AC-DC power factor

correction rectifier based on SEPIC and cuk topologies was described in the topologies were designed to work in discontinuous conduction mode to archive almost unity power factor in a simple and effective manner. Various bridgeless SEPIC and cuk converter are proposed in the literature which result in low voltage stress, improved thermal management and low conduction losses, which are not suitable for low power SMPS application the output voltage range is fairly large. A SEPIC and cuk converters working as power factor pre-regulators in discontinuous conduction mode presented the desirable c/s such as the converter work as a voltage follower, power factor is unity, the output current ripple was defend at the design stage. A simple single phase bridgeless SEPIC rectifier with low input current distortion and low conduction losses' bridgeless buck-boost converter that uses three switches in the conduction loss. A half-bridge voltage source inverter is used at the output for high frequency isolation and multiple dc output voltage in computer power supplies.

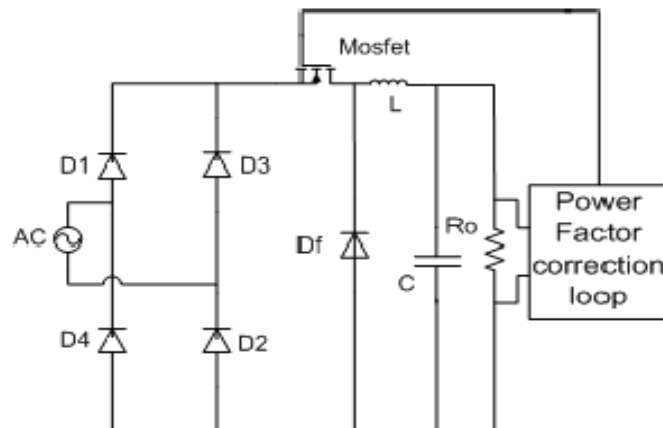

Figure 1. Two Stage AC-DC PFC

## 2. PROPOSED SMPS CIRCUIT CONFIGURATION AND OPERATION.

A proposed SMPS of configuration based multiple output bridgeless converter using single-phase ac

supply uncontrolled diode bridge rectifier that convert ac voltage to dc voltage. The diode rectifier output is connected to bridgeless buck-boost converter. The working of the proposed SMPS configuration are divided into two subsections and presented as follow

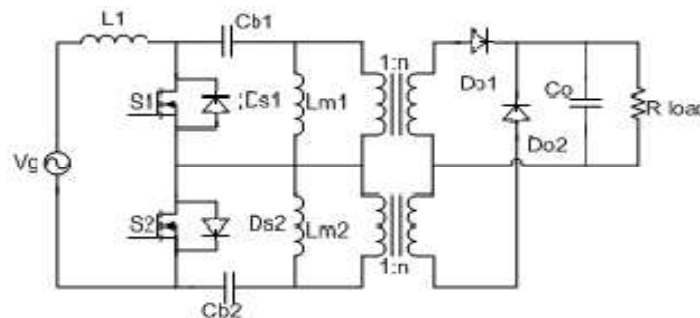

Figure 2. The Proposed Converter

### 2.1. Buck-Boost converter of operation-

The buck-boost converter a type of DC-DC converter that has output voltage that is either greater than or less than the input voltage magnitude thermal management and low conduction losses, which are not suitable for low power SMPS application the output voltage range is fairly large. A SEPIC and cuk convert working as power factor pre-regulators in c/s such as the converter work as a voltage follower, power factors is unity, the output current ripple was defined at the

design stage. A simple single-phase bridgeless SEPIC. Bridgeless buck-boost converters. A half-bridge voltage source inverter is used at the output for high frequency isolation and multiple power supplies and it is cast effective compared to push-pull and full-bridge converter the upper and lower buck-boost converter are switched on and off the positive and negative half cycle of the ac volt. The upper buck-boost converter operation of the positive half cycle of the ac input voltage. The lower buck-boost converter operation of the negative half cycle [5].

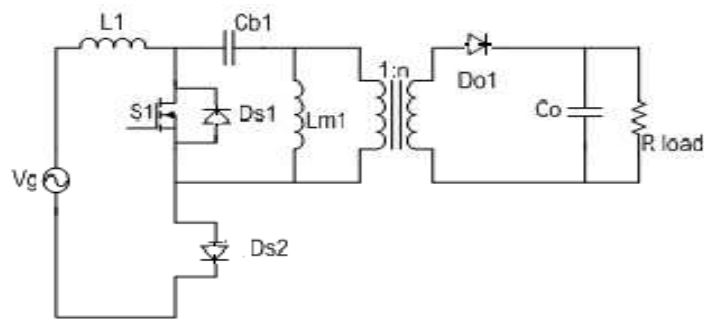

Figure 3. The proposed operated at positive

**2.2. Half-bridge VSI operation**

The half bridge VSI are high frequency isolation the DC output voltage of buck-boost converter. The DC to AC power the upper switch s1 is turned on, diode D1, D3, D5, D7 start conducting the isolated SEPIC dc-dc converter the four secondary winding frequency transformer high frequency

diode D1,D2,D3,D4,D5,D6,D7, D8 and output filter capacitors C01, C02,C03,C04 respectively. A SEPIC stores the energy in an inductor and transformer that energy to the output storage capacitor. When the energy stored in the inductor their maximum values. Thesame operating states respect in each switching cycle.

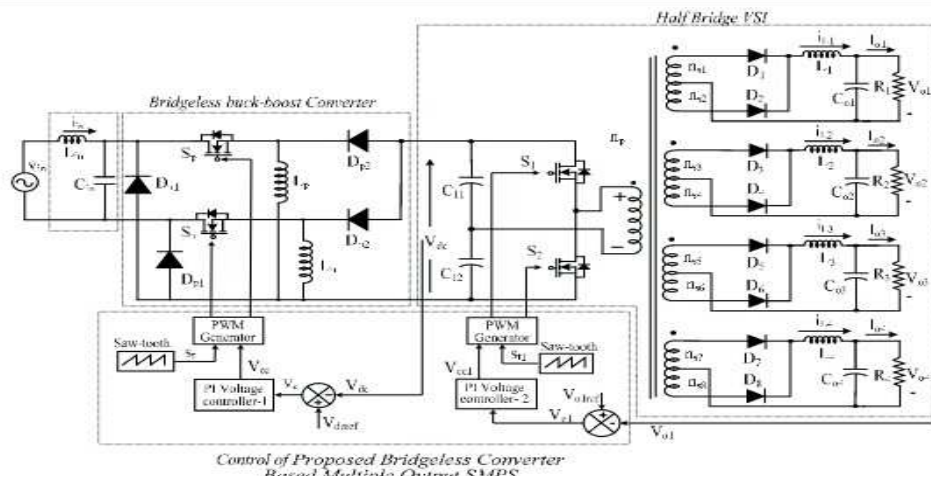

Figure 4-Bridgeless converter based multiple output SMPS

**3. Design of proposed bridgeless converter based SMPS using AC-DC converter-**

The proposed PFC based SMPS are presented the design of switching frequency is very high compared with the frequency line. The steady state analysis of the two stage AC-DC converter based SMPS. A non-isolated AC-DC buck-boost converter is isolated SEPIC.

**3.1 Design of non-isolated DC-DC converter-**

The design of a non-isolated back-boost converter is discontinuous conduction mode (DCM) to input converter is designed in SMPS and the calculating different component values is out for the highest rated output [2]. When both high frequency switches (s2 and s3) are off.

$$L_{o1} = V_{o1} (0.5 - D_n) / f_h \times \Delta_{iL_{o1}} \quad (1)$$

Where  $T_N = 1/f_n$  is the switching time for one PWM cycle,  $V_{dc}$  capacitor value is calculated

$$C = I_{dc} / 2W \Delta V_{dc} \quad (2)$$

The values of c1 and c2 connected in series. The proposed SMPS are different component are used

in modeling

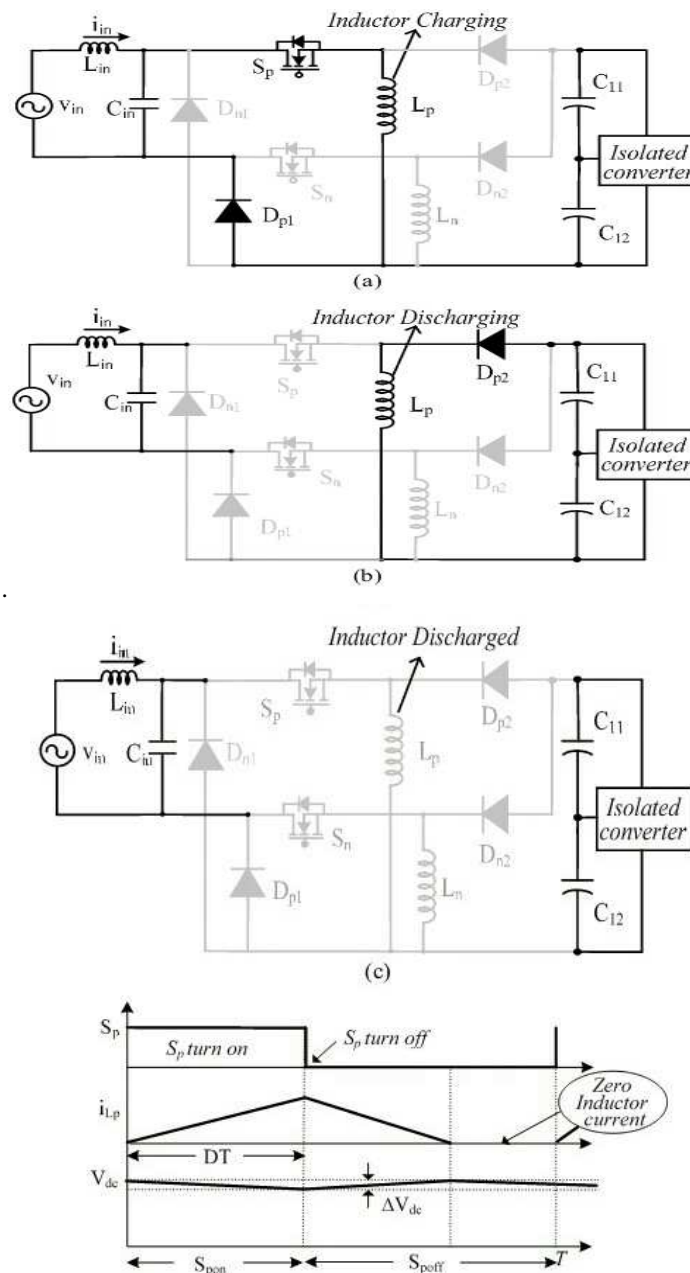

Figure 5. Operating modes for under  
 (a) upper switch  $S_p$  is on, (b) upper switch  $S_p$  is off, (c) both switch and diode are off, (d) wave forms in one switching cycle

### 3.2 Design of input filter

The higher order harmonics in the proposed SMPS, it is use of filter to reduce the harmonic distortion of the ac supply

$$C_{max} = I_m \tan \theta / 2 \times p \times f \times V_m \quad (3)$$

Where  $I_m$  and  $V_m$  are the input ac current and ac voltage.

The low harmonic distortion at input ac-

$$L_d = 1/4 \times \pi^2 \times f_c^2 \times C_d \quad (4)$$

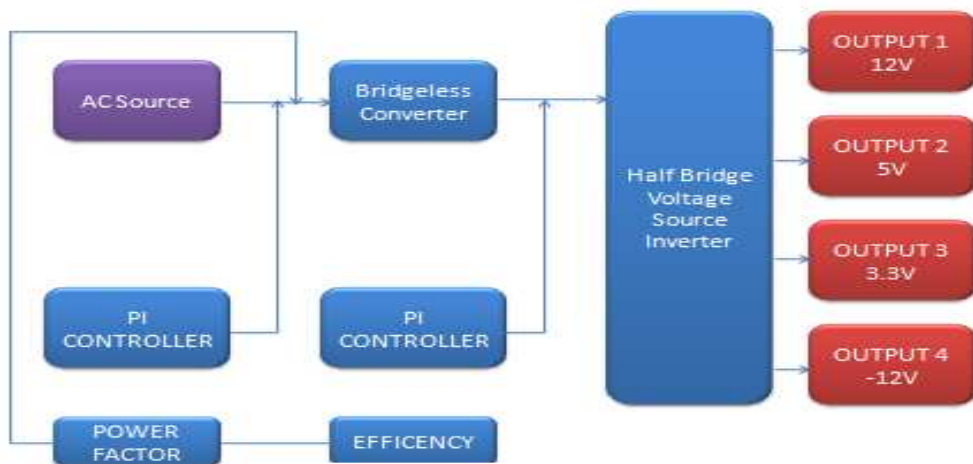

Figure 6. Block diagram implementing PI Controller

#### 4. Control of proposed Bridgeless converter based multiple output SMPS

##### 4.1 Pulse generator PWM

The PWM pulse generator the output of PI controller the fixed high frequencies saw-tooth ramp is the output of the PI controller saw tooth ramp is less than the switch turn on, it is off.

##### 4.2 Isolated SEPIC for control

The output voltage as input voltage to the SEPIC is DC voltage. The control of SEPIC is carried out

in continuous conduction mode (CCM) to reduce. The consist of one PI controller and PWM pulse generator [10].

##### 4.3 Non-isolated buck-boost converter for control

The non-isolated buck-boost converter is designed in DCM. The sensor to sense input current and voltage to regulate the output voltage of the converter. The PWM generator to obtain the ON/OFF control pulse [9].

#### 5. MODELING AND SIMULATION

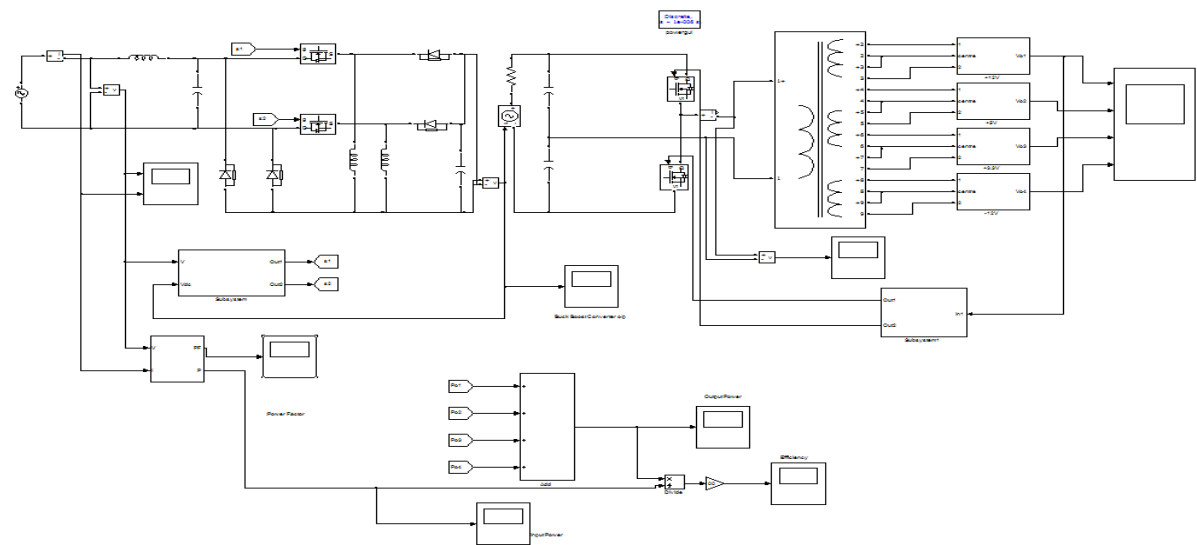

Figure 7. MATLAB/Simulation of improved bridgeless converter based multiple output SMPS

## 6. ADVANTAGE

1. It will minimize the maximum overshoot
2. Improve Power quality
3. Increased Efficiency

## 7. APPLICATION

1. Computer&other similarAppliance's.
- 2.Mobile phone charge.

## 8. RESULT AND DISCUSSION

This section, simulation results of an improved power quality SMPS using bridgeless converter

and discussed in details. To study the performance of the SMPS and if various power quality with specified limits. The simulated waveform of the SMPS, a step change in loads  $i_d$  applied simultaneously on +12V and +5 output. The load on +12V output is varied from 100% to 20%.at 0.15 and simultaneously in +5V, it is varied from 100% to 70% at 0.25s. The output voltage of the buck-boost converter is maintained constant with a small overshoot. Multtipul output dc voltage remain constant. THD of the input ac mains current is observed as 5.14% the input current harmonics content is within international standard limits with unity PF at the utility interface.

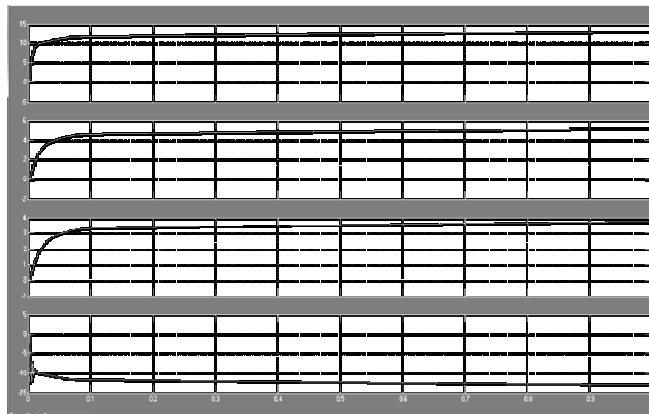

Figure 8. Input voltage, current, bridgeless buck-boost converter output voltage half bridge VSI output voltage.

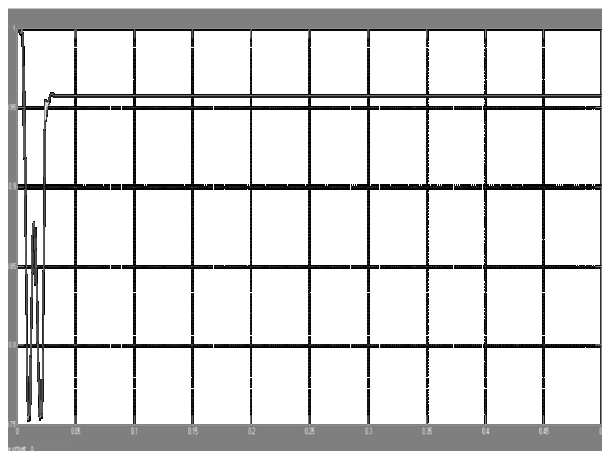

Figure 9. Output Efficiency of the implemented circuit

The experimentally obtained efficiency of the implemented circuit, as function of the output power,

Whose minimum value is greater than 80%. The efficiency can be improved by the employment of a soft commutation technique.

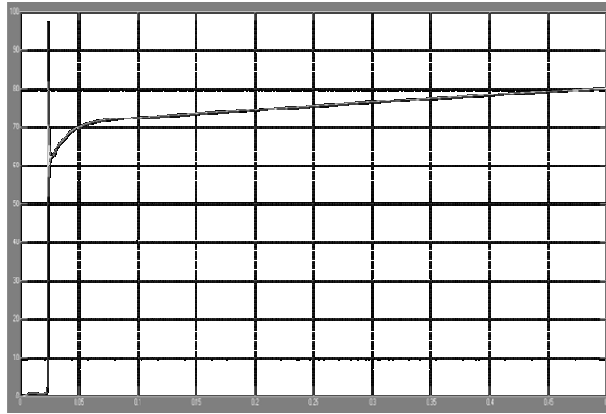

Figure 10. Power factor output

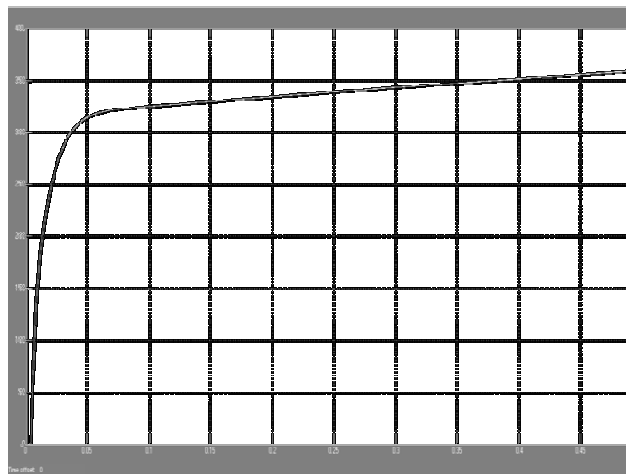

Figure 11. Output voltage of the converter

## 9. CONCLUSION & FUTURE SCOPE

An improved power quality SMPS for personal computer application. The input current THD of over 83.5% and PF of less than 16.5 at the utility interface under varying input voltage. It is used to DC-DC converter has been designed and modeled. The first stage DC voltage of the buck-boost converter has been maintained constant, independent of the input voltage is changes. Half-bridge DC-DC converter is used for obtained multiple DCoutput at the second stage.In Future,

the same design can be implemented using Neural Network for more efficient output results.

## ACKNOWLEDGEMENT

Authors would like to acknowledge the Department of Science and Technology, Government of India for the research grant for the project "Power Quality Improvement", under the guidance received from staff of Electronics department of MatsSchool of Engineering & I.T. I would like to deeply thank ourHead of Department Mr. M K Pradhan and my Guide Mr.Alok sahu and M.Tech coordinator Mr.

G S Rathore forgiving me the opportunity to apply and share my knowledge in this field. I would also like to thank all the faculties of our department & every person who have helped me for this paper presentation.

#### **REFERENCES**

- [1] Ismail; E.H;April (2009):Bridgeless SEPIC rectifier with unity power factor and reduced conduction losses, IEEE Trans. Industrial Electronics, vol. 56, no.4, pp.1147-1157.
- [2] Qian Li.;Lee F.C.;Ming Xu, Chuanyun Wang.;Expositon, (2009)Performance evaluation of bridgeless PFC boost rectifiers,IEEE Energy Conversion Congress,pp. 3755-3760
- [3] Abe S.;Yamamoto j.;Zeist Tandy Ninomiya T. (2003). Extension of bandwidth of two-stage dc-dc converter with low-voltage/high-current output.Proctor IEEE PESC, Vol.4, pp.1593-1598.
- [4] R. KELLER and G. BAKER P (1984) Unity power factor off line switching power supplies, pp.332-339.
- [5] K.Matsui; I Yamamoto.; T.Kishi, M.Hasegawa, H.Mori and F.Ueda,I.(02,2002) A comparison of various buck-boost converter and their application to PFC,in 28<sup>th</sup> conf.IEEE IECON, vol.1, pp.30-36.
- [6] N. Mohan.; T. M. Undeland and W. P. Robbins, U (2003) Power Electronics: Converters, Applications and Design, John Wiley and Sons Inc.
- [7] P.J.Moore;I.E.Portuguesa.;O.(2003) TheInfluence of personal computer processing mode on line current harmonics”, IEEE Trans. Power Delivery, vol. 18, no. 4, pp. 1363-1368, Oct 2003. Journal Of Innovative Research & Development Page 608
- [8] Qian Li.; Lee F.C.; Ming Xu, Chuanyun Wang.;E.(2009) Light load efficiency improvement for PFC, IEEE Energy Conversion Congress, pp. 3755-3760